

# COTTONWOOD RIDGE ANNEXATION AND CONCEPTUAL MASTER PLAN LAYOUT

STAYTON, OREGON

IN THE NE 1/4  
SEC 11, TOWNSHIP 9 SOUTH, RANGE 1 WEST, W.M.  
MARION COUNTY, OREGON  
TAX MAP 09 1W 11A

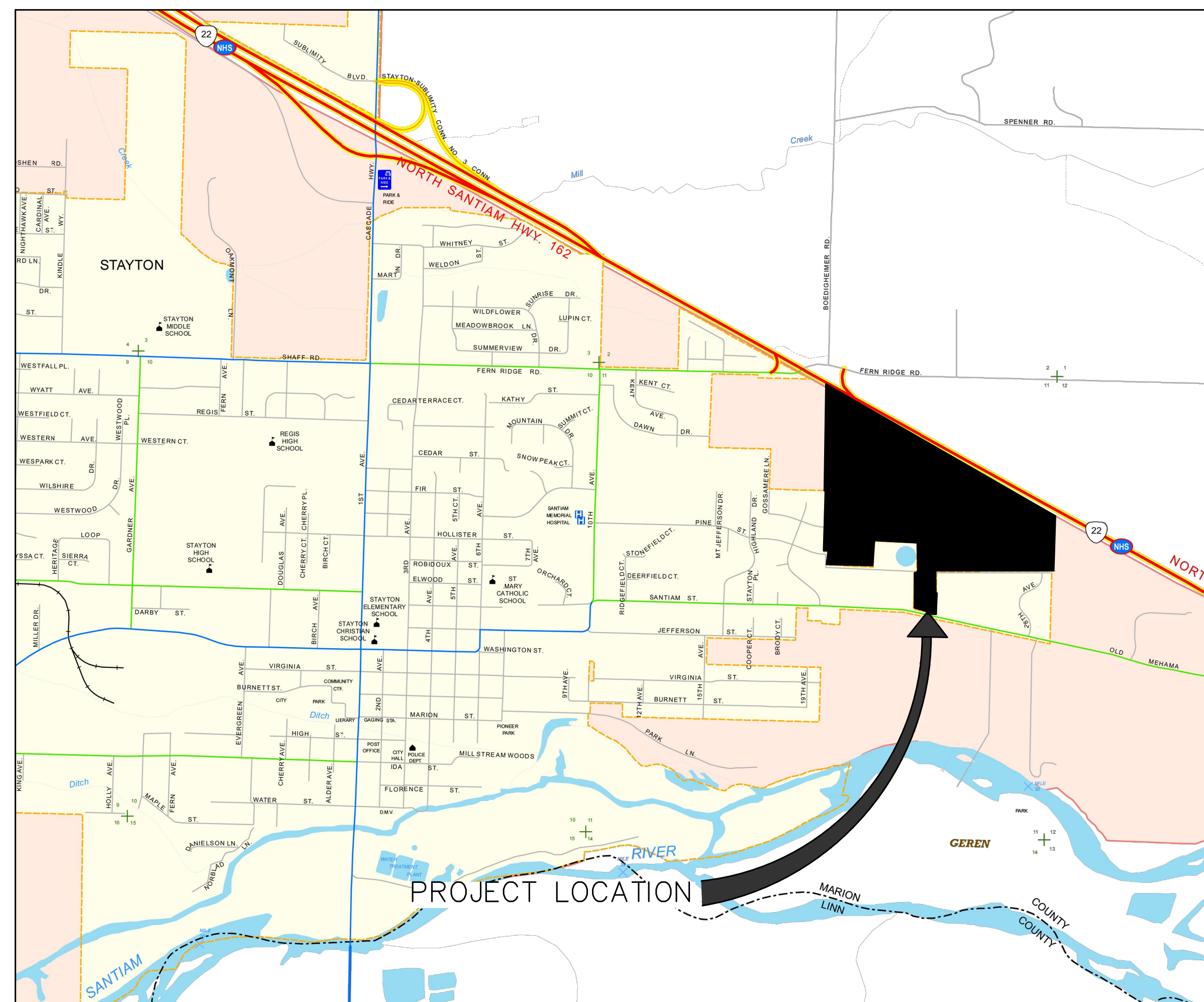

VICINITY MAP  
NTS

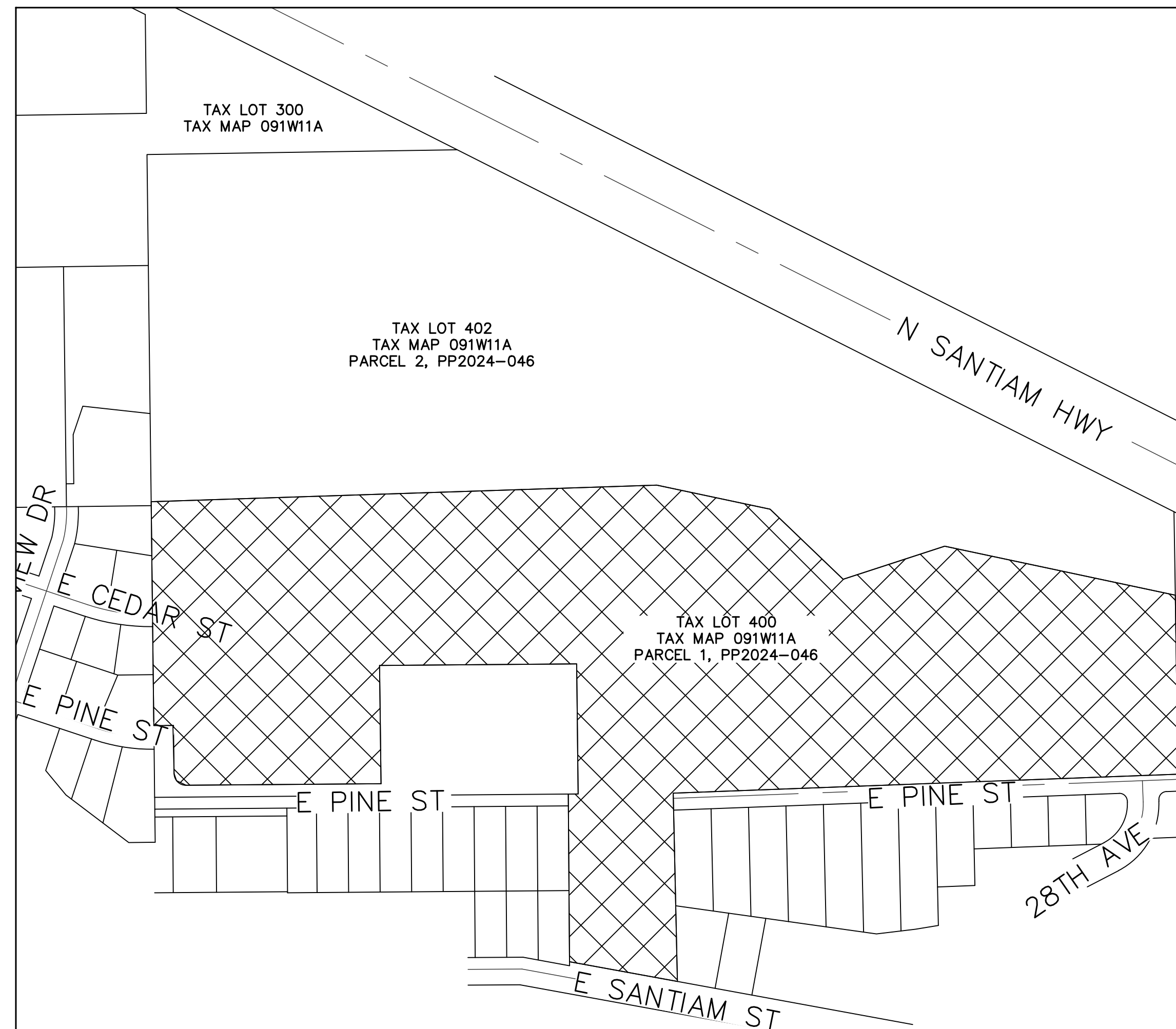

PROJECT LOCATION  
1" = 250'

**OWNER:**

THE KARDBOARD BOX LLC  
PO BOX 617  
STAYTON, OR 97383

**PLANNING:**

ROSS BOCHSLER  
PO BOX 516 STAYTON, OR 97383  
ROSSB@NSPOR.COM  
503-769-3436

**ENGINEER:**

NORTH SANTIAM PAVING  
LEVI WARRINER  
PO BOX 516 STAYTON, OR  
LEVIW@NSPOR.COM  
503-769-3436

**SURVEYOR:**

NORTH SANTIAM PAVING  
MICHAEL DOWNS  
PO BOX 516 STAYTON, OR  
MICHAELD@NSPOR.COM  
503-769-3436

**SHEET INDEX:**

C100:	COVER SHEET
C101:	ANNEXATION AREA
C102:	ANNEXATION AREA
C200:	EXISTING CONDITIONS
C201:	EXISTING CONDITIONS
C202:	EXISTING CONDITIONS
C203:	EXISTING CONDITIONS
C204:	EXISTING CONDITIONS
C205:	EXISTING CONDITIONS
C300:	CONCEPTUAL PLAN OVERALL
C301:	CONCEPTUAL PLAN OVERALL
C302:	CONCEPTUAL PLAN
C303:	CONCEPTUAL PLAN
C304:	CONCEPTUAL PLAN
C305:	CONCEPTUAL PLAN

**PERMITS:**

**ELEVATION DATUM:**

THE ELEVATION DATUM IS BASED ON A MARION COUNTY ALUMINUM CAP STAMPED "MARION COUNTY SURVEYOR T9SR1WS11 9467 1994" WITH AN ELEVATION OF 567.50 FEET (NAVD88). IT IS LOCATED AT THE NORTHWEST CORNER OF THE FENCE THAT SURROUNDS THE WATER TANK ON E PINE STREET IN STAYTON, OREGON.

**ATTENTION EXCAVATORS:**

OREGON LAW REQUIRES YOU TO FOLLOW RULES ADOPTED BY THE OREGON UTILITY NOTIFICATION CENTER. THOSE RULES ARE SET FORTH IN OAR 952-001-0010 THROUGH OAR 952-001-0090. YOU MAY OBTAIN COPIES OF THESE RULES FROM THE CENTER BY CALLING 503-232-1987. IF YOU HAVE ANY QUESTIONS ABOUT THE RULES, YOU MAY CONTACT THE CENTER. YOU MUST NOTIFY THE CENTER AT LEAST TWO BUSINESS DAYS BEFORE COMMENCING AN EXCAVATION. CALL 503-246-6699.

**NS** NORTH SANTIAM PAVING COMPANY  
503-769-3436  
LEVIW@NSPOR.COM  
CONSTRUCTION • ENGINEERING • SURVEYING

COTTONWOOD RIDGE  
CITY OF STAYTON  
MARION COUNTY, OREGON  
NE 1/4 SEC 11 T9S R1W 11W TAX MAP 091W11A TAX LOT 400

**COVER SHEET**

REGISTERED PROFESSIONAL ENGINEER  
88956PE  
PRELIMINARY  
JANUARY 21, 2021  
LEVI D. WARRINER  
EXPIRES: 6-30-2026  
PLOT DATE: 5/15/2026  
REVISIONS:  
DRAWN BY: LDW  
CHECKED BY: LDW  
JOB No: 20115  
SCALE: AS NOTED  
SHEET  
**C100**

TAX LOT 300  
TAX MAP 091W11A

TAX LOT 402  
TAX MAP 091W11A  
PARCEL 2, PP 2024-046  
37.07 AC

TAX LOT 400  
TAX MAP 091W11A  
PARCEL 1, PP 2024-046  
38.96 AC

TAX LOT 100  
TAX MAP 091W11AC  
CITY OF STAYTON

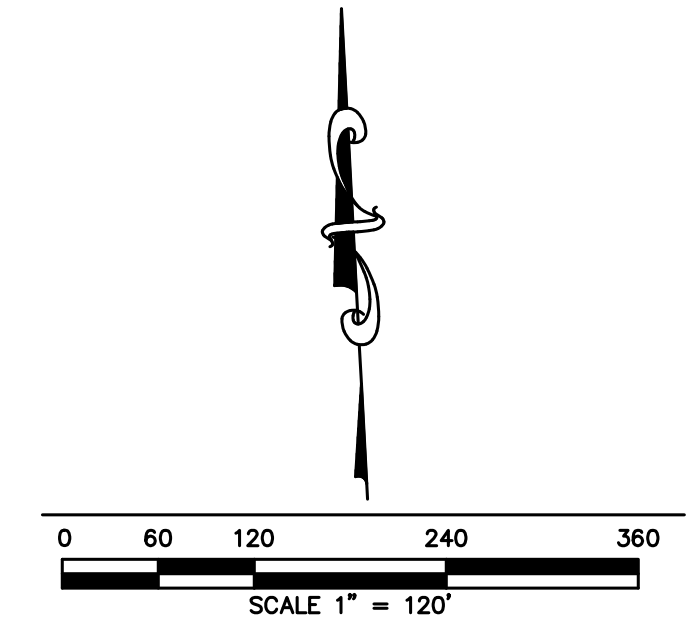

GENERAL NOTES:

1. THE PURPOSE OF THIS PLAN IS TO SHOW PARCEL 1 OF PP 2024-046 ANNEXATION INTO CITY LIMITS.

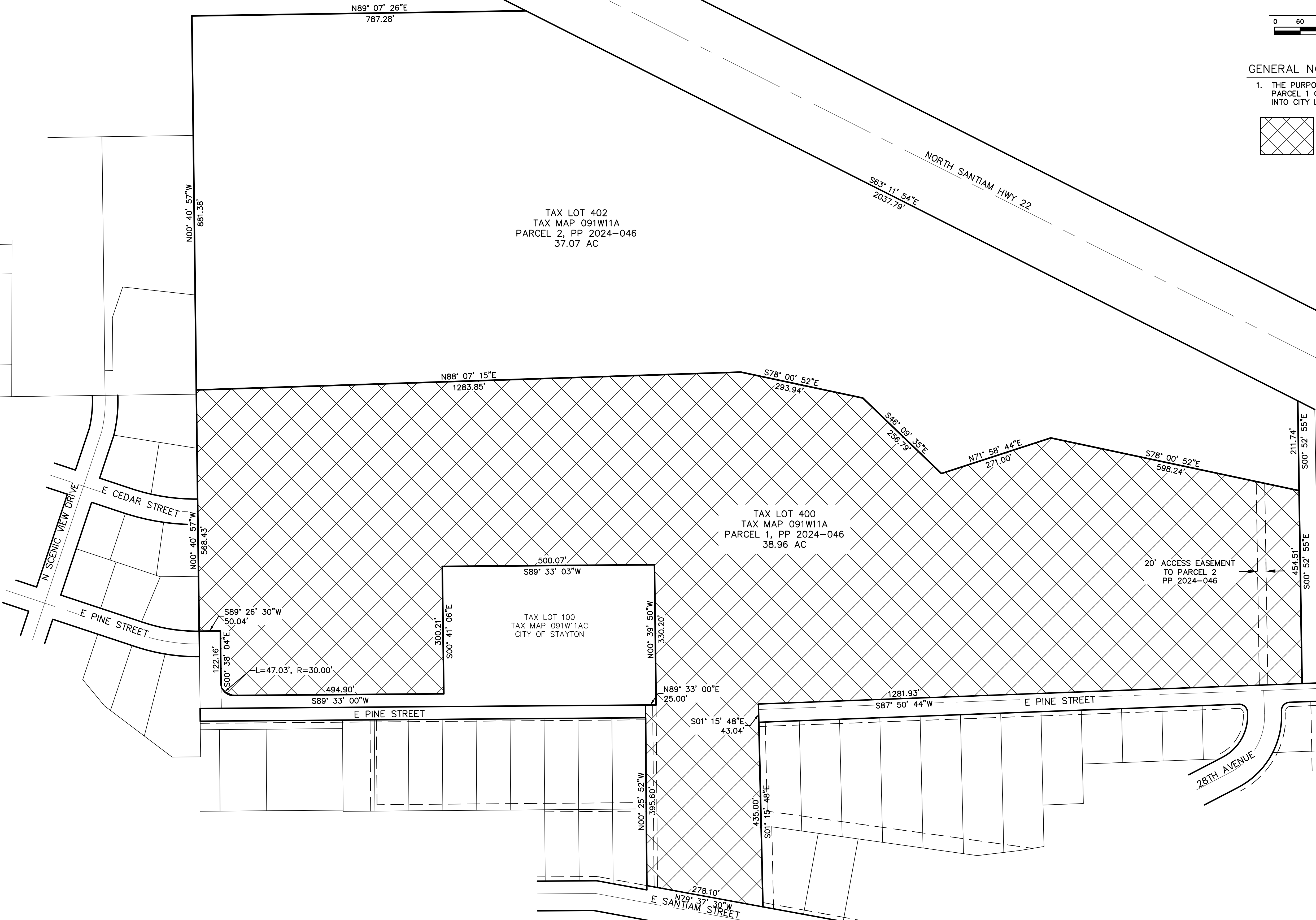
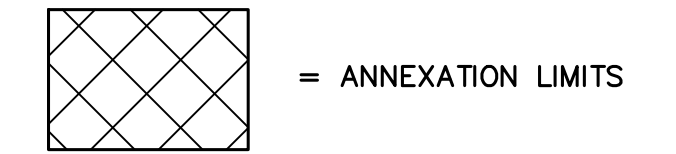

**NS** NORTH SANTIAM PAVING COMPANY  
 (503) 769-3436  
 LEVIN@SPOR.COM  
 41203 KINGSTON-LYONS DRIVE, P.O. BOX 516  
 STAYTON, OREGON 97383  
 CONSTRUCTION • ENGINEERING • SURVEYING

**COTTONWOOD RIDGE**  
 CITY OF STAYTON MARION COUNTY, OREGON  
 NE 1/4 SEC 11 T9S R1W 1W TAX MAP 091W11A TAX LOT 400

**ANNEXATION AREA**



EXPIRES: 6-30-2026  
 PLOT DATE: 5/15/2026  
 REVISIONS:  
 DRAWN BY: LDW  
 CHECKED BY: LDW  
 JOB No: 20115  
 SCALE: 1" = 120'

SHEET  
**C101**

GENERAL NOTES:

- 1. THE PURPOSE OF THIS PLAN IS TO SHOW PARCEL 1 OF PP 2024-046 ANNEXATION INTO CITY LIMITS.

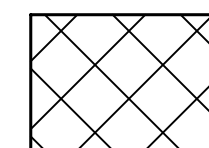

= ANNEXATION LIMITS

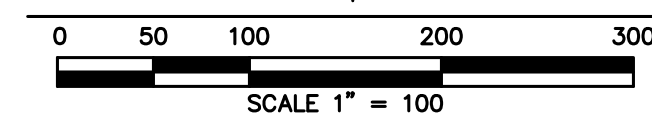

TAX LOT 402  
 TAX MAP 091W11A  
 PARCEL 2, PP 2024-046  
 37.07 AC

TAX LOT 400  
 TAX MAP 091W11A  
 PARCEL 1, PP 2024-046  
 38.96 AC

TAX LOT 100  
 TAX MAP 091W11AC  
 CITY OF STAYTON



**NS** NORTH SANTIAM PAVING COMPANY  
 (503) 769-3436  
 LEVIN@NSPC.COM  
 41203 KINGSTON-LYONS DRIVE, P.O. BOX 516  
 STAYTON, OREGON 97383  
 CONSTRUCTION • ENGINEERING • SURVEYING

**COTTONWOOD RIDGE**  
 CITY OF STAYTON MARION COUNTY, OREGON  
 NE 1/4 SEC 11 T9S R1W 11M TAX MAP 091W11A TAX LOT 400

**ANNEXATION AREA**



EXPIRES: 6-30-2026  
 PLOT DATE: 5/15/2026  
 REVISIONS:

DRAWN BY: LDW  
 CHECKED BY: LDW  
 JOB No: 20115  
 SCALE: 1" = 100'

SHEET  
**C102**

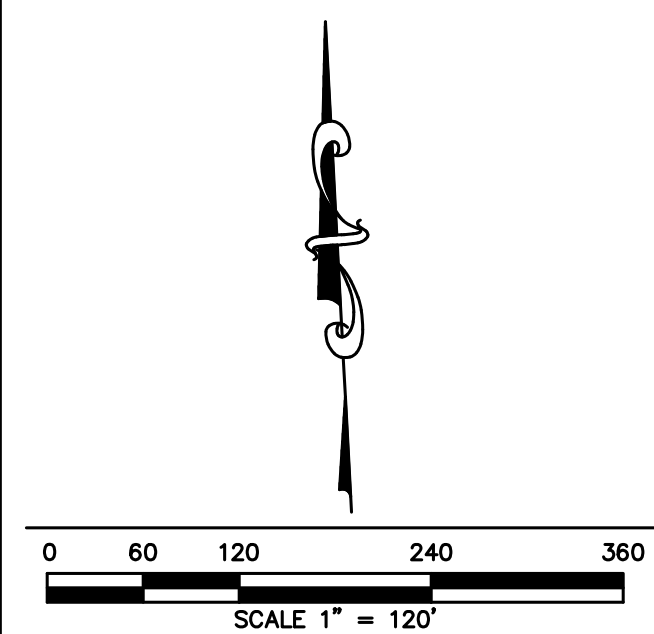

**GENERAL NOTES:**

1. THIS MAP DOES NOT CONSTITUTE A PROPERTY BOUNDARY SURVEY.
2. CONTOURS AT 1' INTERVALS.
3. THE LOCATION AND DESCRIPTIONS OF EXISTING UTILITIES SHOWN ON THE DRAWINGS ARE COMPILED FROM AVAILABLE RECORDS AND/OR FIELD SURVEYS. THE ENGINEER OR UTILITY COMPANIES DO NOT GUARANTEE THE ACCURACY OR THE COMPLETENESS OF SUCH RECORDS. CONTRACTOR SHALL FIELD VERIFY SIZES AND LOCATIONS OF ALL EXISTING UTILITIES PRIOR TO CONSTRUCTION.
4. SEE SH C201-205 FOR MORE DETAILS.

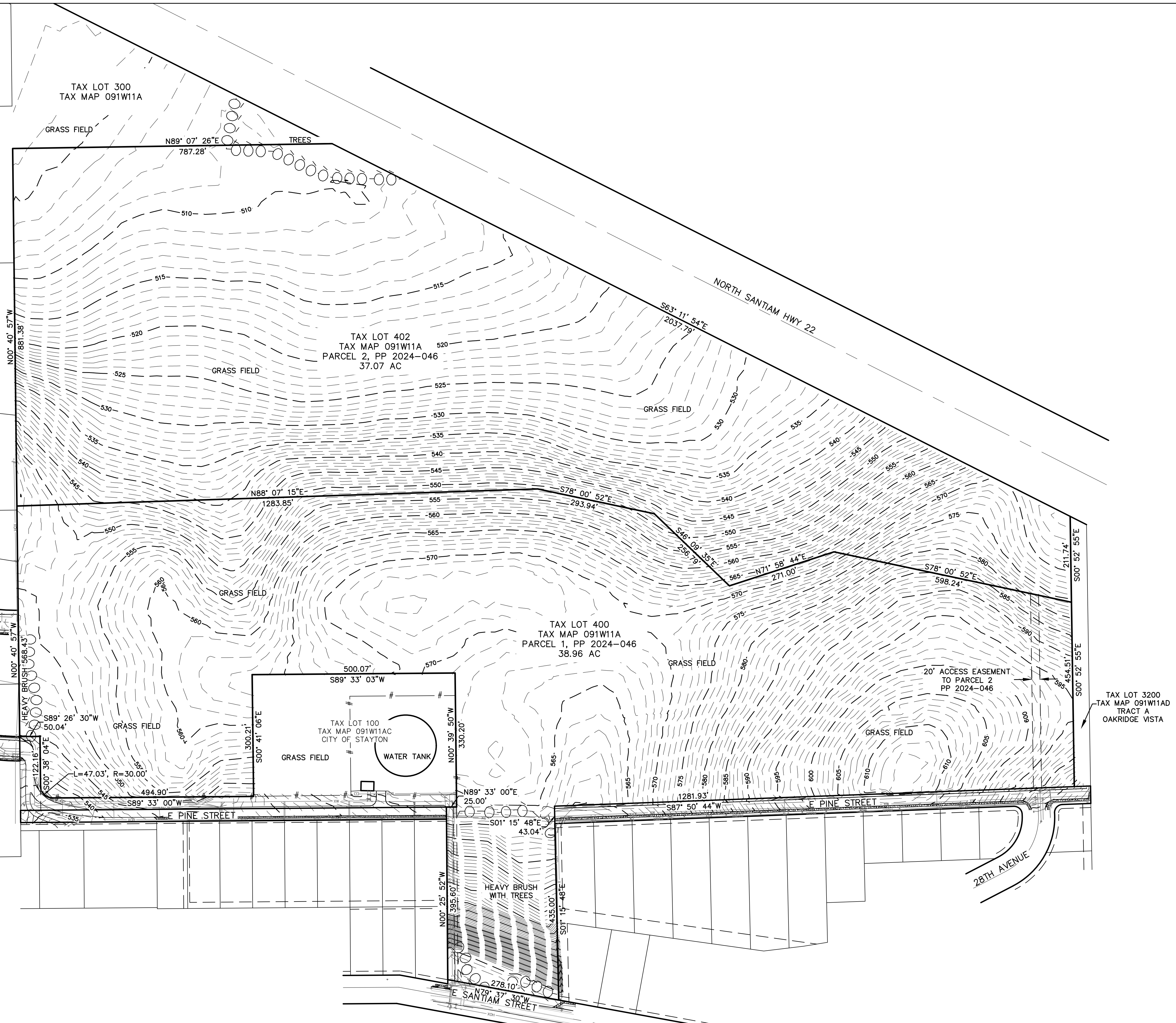

**NS** NORTH SANTIAM PAVING COMPANY  
 (503) 769-3436  
 LEVIN@NSPOR.COM  
 41203 KINGSTON-LYONS DRIVE, P.O. BOX 516  
 STAYTON, OREGON 97383  
 CONSTRUCTION • ENGINEERING • SURVEYING

**COTTONWOOD RIDGE**  
 CITY OF STAYTON MARION COUNTY, OREGON  
 NE 1/4 SEC 11 T9S R1W W4 TAX MAP 091W11A TAX LOT 400

**EXISTING CONDITIONS**

REGISTERED PROFESSIONAL ENGINEER  
 88956PE  
**PRELIMINARY**  
 JANUARY 21, 2021  
 LEVI D. WARRINER

EXPIRES: 6-30-2026  
 PLOT DATE: 5/15/2026  
 REVISIONS:

DRAWN BY: LDW  
 CHECKED BY: LDW  
 JOB No: 20115  
 SCALE: 1" = 120'

SHEET  
**C200**

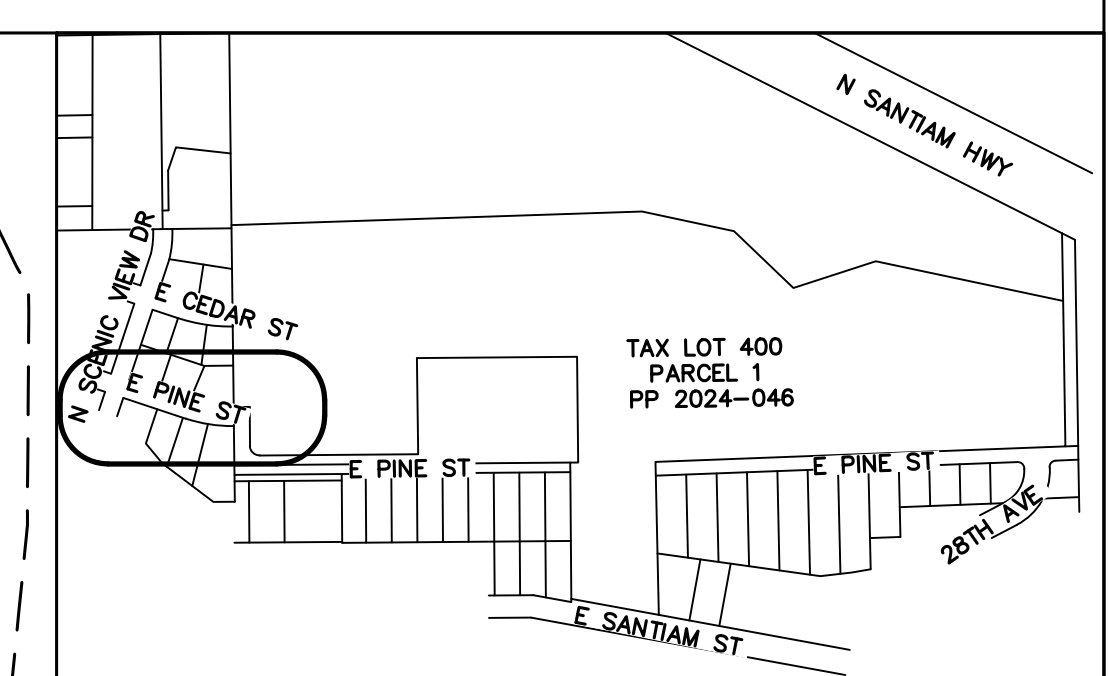
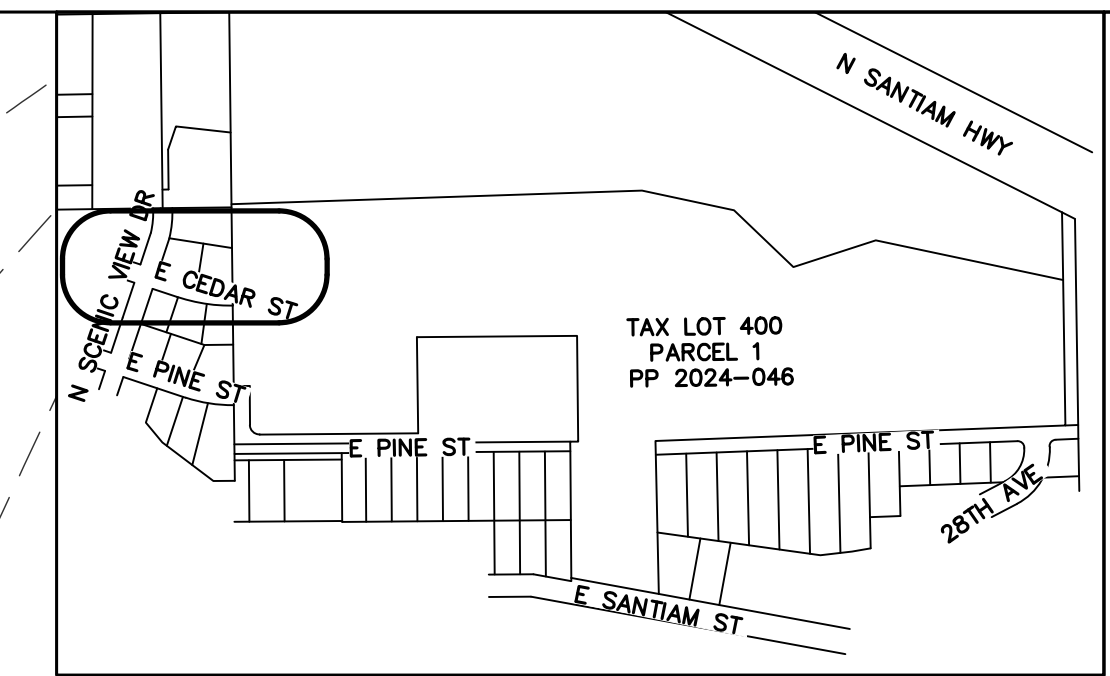
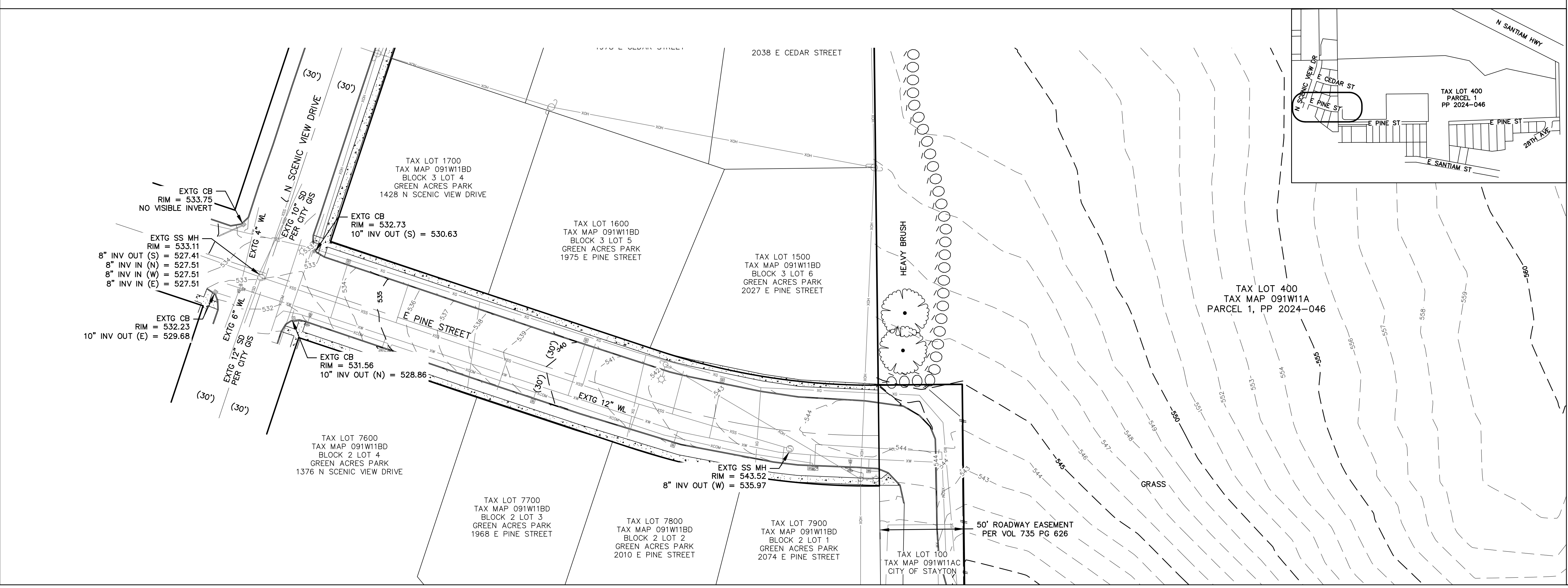
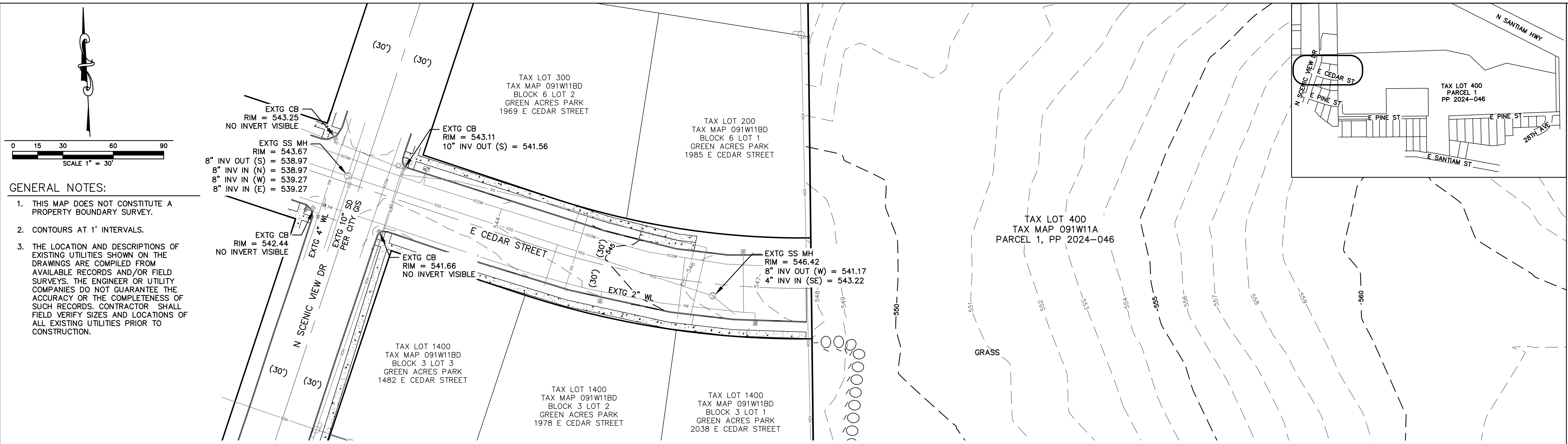

**NS** NORTH SANTIAM PAVING COMPANY  
 (503) 769-3436  
 LEVIN@NSPC.COM

CONSTRUCTION • ENGINEERING • SURVEYING

**COTTONWOOD RIDGE**

CITY OF STAYTON MARION COUNTY, OREGON  
 NE 1/4 SEC 11 T9S R1W 11M TAX MAP 091W11A TAX LOT 400

**EXISTING CONDITIONS**

REGISTERED PROFESSIONAL ENGINEER  
 88956PE  
**PRELIMINARY**  
 OREGON  
 JANUARY 21, 2021  
 LEVI D. WARRINER

EXPIRES: 6-30-2026

PLOT DATE: 5/15/2026

REVISIONS:



DRAWN BY: LDW  
 CHECKED BY: LDW

JOB No: 20115

SCALE: 1" = 30'

SHEET  
**C201**

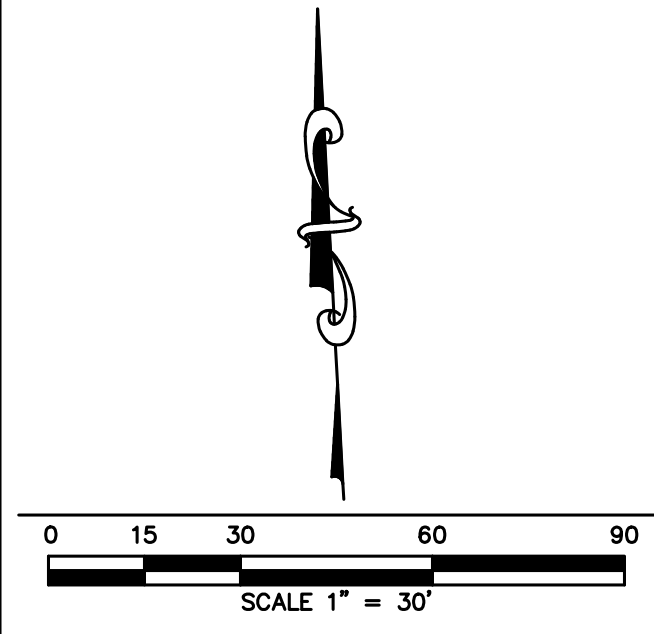



- GENERAL NOTES:**
1. THIS MAP DOES NOT CONSTITUTE A PROPERTY BOUNDARY SURVEY.
  2. CONTOURS AT 1' INTERVALS.
  3. THE LOCATION AND DESCRIPTIONS OF EXISTING UTILITIES SHOWN ON THE DRAWINGS ARE COMPILED FROM AVAILABLE RECORDS AND/OR FIELD SURVEYS. THE ENGINEER OR UTILITY COMPANIES DO NOT GUARANTEE THE ACCURACY OR THE COMPLETENESS OF SUCH RECORDS. CONTRACTOR SHALL FIELD VERIFY SIZES AND LOCATIONS OF ALL EXISTING UTILITIES PRIOR TO CONSTRUCTION.
  4. SEE SH C205 FOR TREE INVENTORY.

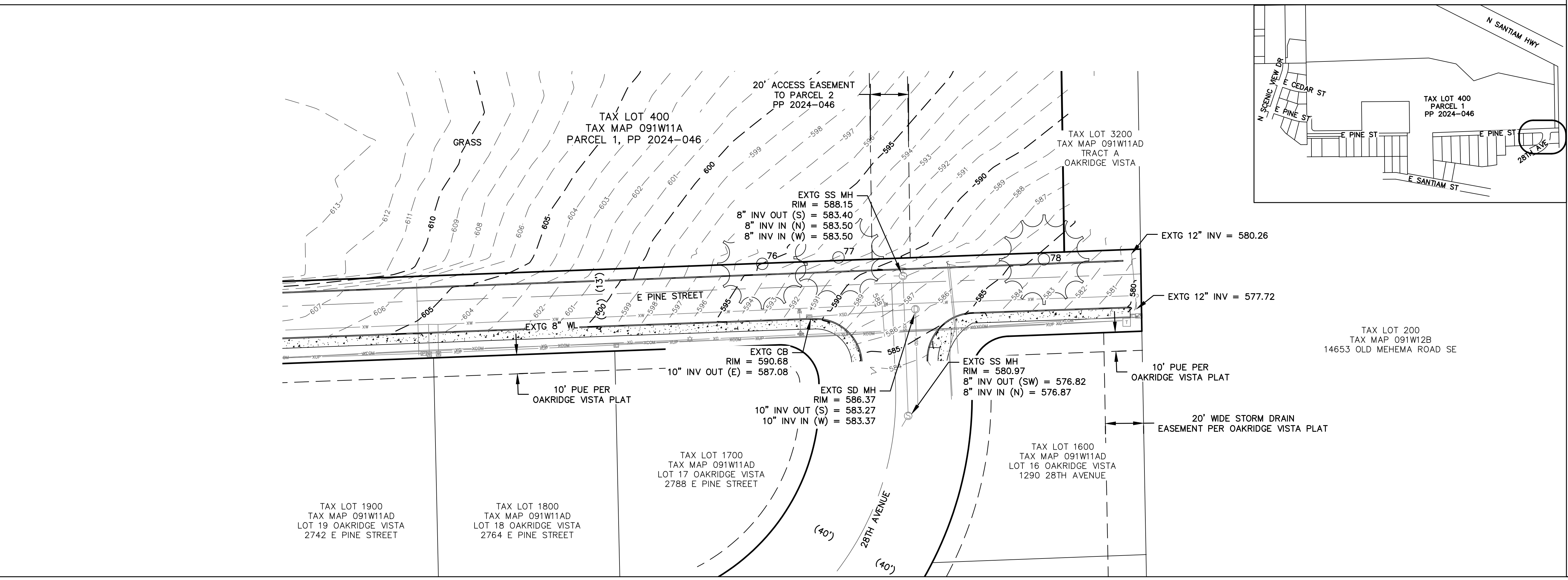
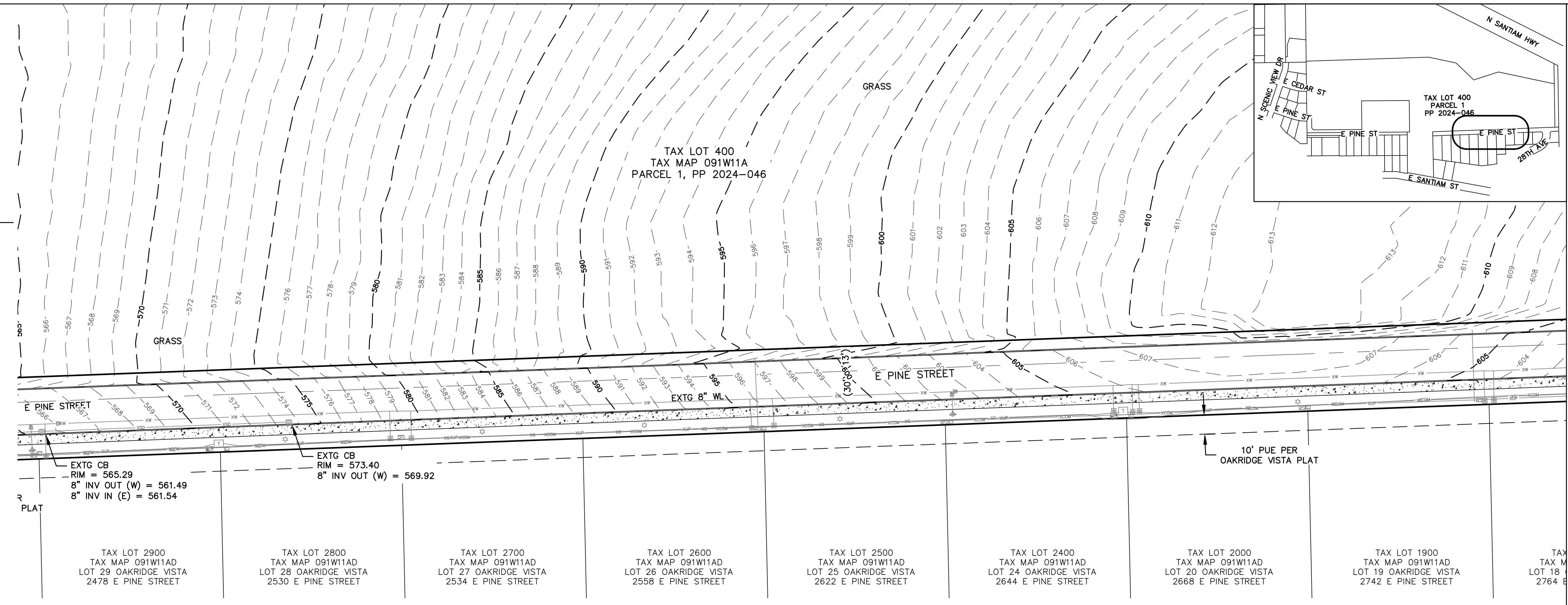

**NS** NORTH SANTIAM PAVING COMPANY  
 (503) 769-3436  
 LEVIN@NSPOR.COM  
 41203 KINGSTON-LYONS DRIVE, P.O. BOX 516  
 STAYTON, OREGON 97383  
 CONSTRUCTION • ENGINEERING • SURVEYING

**COTTONWOOD RIDGE**  
 CITY OF STAYTON MARION COUNTY, OREGON  
 NE 1/4 SEC 11 T9S R1W 11M TAX MAP 091W11A TAX LOT 400

**EXISTING CONDITIONS**

REGISTERED PROFESSIONAL ENGINEER  
 88956PE  
 PRELIMINARY  
 JANUARY 21, 2021  
 LEVI D. WARRINER

EXPIRES: 6-30-2026  
 PLOT DATE: 5/15/2026  
 REVISIONS:  
 DRAWN BY: LDW  
 CHECKED BY: LDW  
 JOB No: 20115  
 SCALE: 1" = 30'  
 SHEET  
**C203**

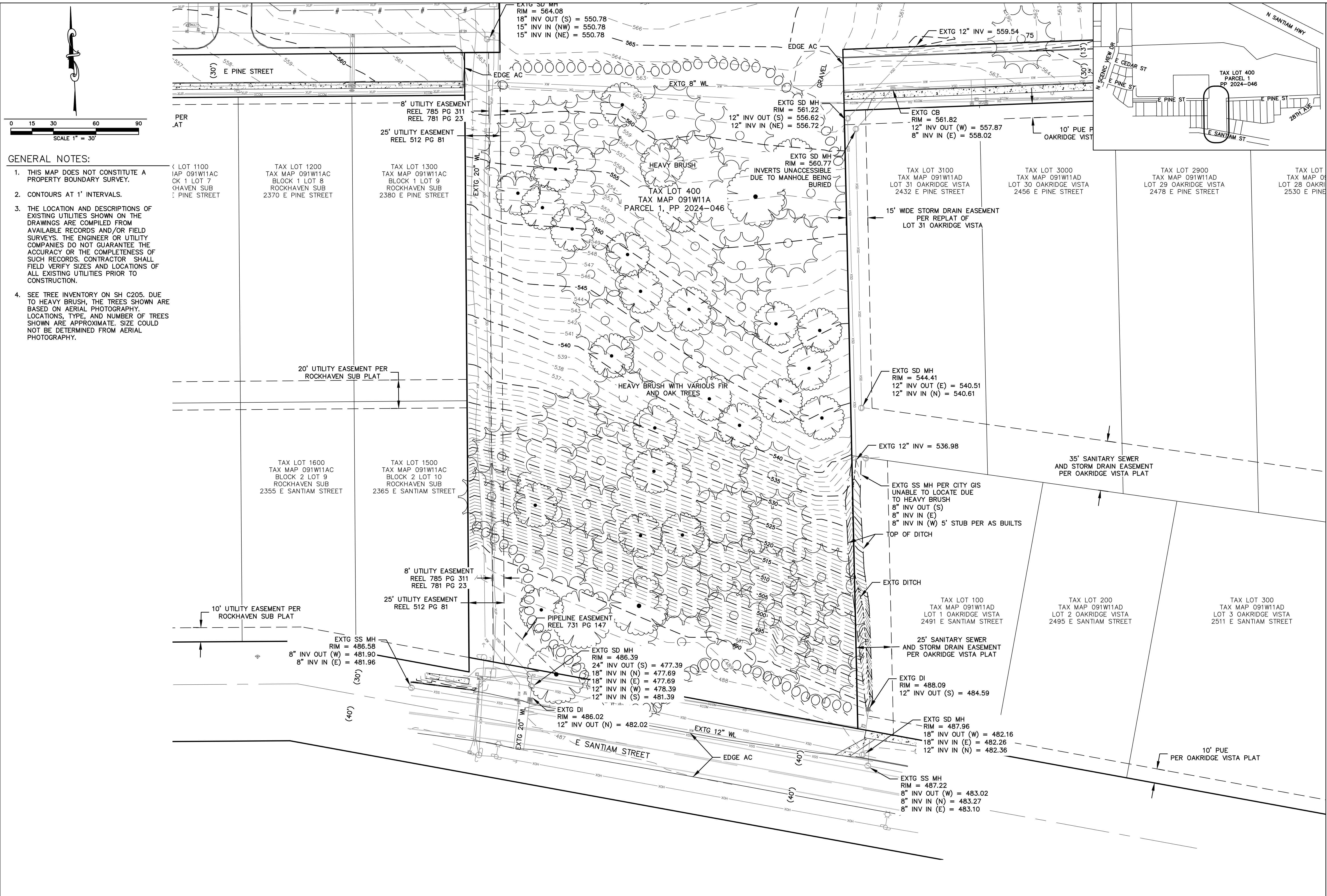

- GENERAL NOTES:**
1. THIS MAP DOES NOT CONSTITUTE A PROPERTY BOUNDARY SURVEY.
  2. CONTOURS AT 1' INTERVALS.
  3. THE LOCATION AND DESCRIPTIONS OF EXISTING UTILITIES SHOWN ON THE DRAWINGS ARE COMPILED FROM AVAILABLE RECORDS AND/OR FIELD SURVEYS. THE ENGINEER OR UTILITY COMPANIES DO NOT GUARANTEE THE ACCURACY OR THE COMPLETENESS OF SUCH RECORDS. CONTRACTOR SHALL FIELD VERIFY SIZES AND LOCATIONS OF ALL EXISTING UTILITIES PRIOR TO CONSTRUCTION.
  4. SEE TREE INVENTORY ON SH C205. DUE TO HEAVY BRUSH, THE TREES SHOWN ARE BASED ON AERIAL PHOTOGRAPHY. LOCATIONS, TYPE, AND NUMBER OF TREES SHOWN ARE APPROXIMATE. SIZE COULD NOT BE DETERMINED FROM AERIAL PHOTOGRAPHY.

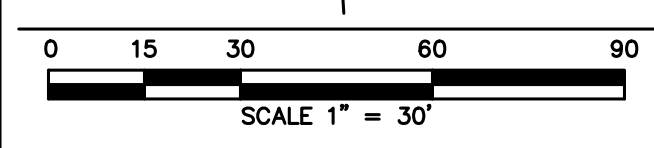

**NS** NORTH SANTIAM PAVING COMPANY  
 (503) 769-3436  
 LEVIN@NSPC.COM

CONSTRUCTION • ENGINEERING • SURVEYING

**COTTONWOOD RIDGE**

CITY OF STAYTON MARION COUNTY, OREGON  
 NE 1/4 SEC 11 T9S R1W 11M TAX MAP 091W11A TAX LOT 400

**EXISTING CONDITIONS**



EXPIRES: 6-30-2026  
 PLOT DATE: 5/15/2026  
 REVISIONS:

DRAWN BY: LDW  
 CHECKED BY: LDW  
 JOB No: 20115  
 SCALE: 1" = 30'  
 SHEET **C204**

**GENERAL NOTES:**

- DIAMETER OF TREE IS BASED ON DIAMETER AT BREAST HEIGHT (DBH).

TREE INVENTORY		
TREE NUMBER	SPECIES	DIAMETER (IN)
1	FIR	24
2	FIR	24
3	FIR	24
4	FIR	20
5	FIR	24
6	FIR	18
7	FIR	20
8	FIR	24
9	FIR	24
10	FIR	18
11	FIR	18
12	FIR	20
13	FIR	12
14	FIR	12
15	FIR	12
16	FIR	12
17	FIR	12
18	FIR	12
19	FIR	8
20	FIR	12
21	FIR	12
22	FIR	12
23	FIR	12
24	FIR	12
25	FIR	12
26	FIR	12
27	FIR	12
28	FIR	12
29	FIR	12
30	FIR	12
31	FIR	12
32	FIR	12
33	FIR	12
34	FIR	8
35	FIR	12
36	FIR	12
37	FIR	12
38	FIR	12
39	FIR	12
40	FIR	12
41	FIR	20
42	FIR	16
43	FIR	12
44	FIR	12
45	FIR	12
46	FIR	12
47	FIR	12
48	FIR	12
49	FIR	12
50	FIR	12
51	FIR	12
52	FIR	12
53	OAK	10
54	FIR	12
55	FIR	12
56	OAK	20
57	FIR	16
58	FIR	12
59	FIR	12
60	FIR	12
61	FIR	16
62	FIR	16
63	FIR	16
64	FIR	16
65	FIR	16
66	FIR	16
67	FIR	16
68	FIR	16
69	FIR	16
70	FIR	16
71	FIR	16
72	FIR	16
73	FIR	16
74	FIR	16
75	OAK	36
76	OAK	24
77	OAK	18
78	OAK	24

**LEGEND**

	EXISTING	EXISTING	
SITE PROPERTY LINE/ROW		STORM MANHOLE	
NEIGHBORING PROPERTY LINE		STORM CATCH BASIN	
CENTER LINE		STORM DITCH INLET	
EASEMENT		SANITARY SEWER MANHOLE	
SANITARY SEWER LINE		WATER METER	
STORM LINE		WATER VALVE	
WATER LINE		WATER BLOWOFF	
GAS LINE		FIRE HYDRANT	
OVERHEAD POWER		WATER VAULT	
UNDERGROUND POWER		LIGHT POLE	
COMMUNICATION LINE		POWER POLE	
FENCE LINE		TRANSFORMER	
GRAVEL		ELECTRICAL PED	
TREE/BRUSH LINE		GUY WIRE	
CONTOUR		COMMUNICATION PED	
CONCRETE		COMMUNICATION VAULT	
		TREE	

**NS** NORTH SANTIAM PAVING COMPANY  
 (503) 769-3436  
 LEVIN@NSP.COM  
 41203 KINGSTON-LYONS DRIVE, P.O. BOX 516  
 STAYTON, OREGON 97383  
 CONSTRUCTION • ENGINEERING • SURVEYING

**COTTONWOOD RIDGE**  
 CITY OF STAYTON MARION COUNTY, OREGON  
 NE 1/4 SEC 11 T9S R1W 1W TAX MAP 091W11A TAX LOT 400

**EXISTING CONDITIONS**

REGISTERED PROFESSIONAL ENGINEER  
 88956PE  
 PRELIMINARY  
 OREGON  
 JANUARY 21, 2021  
 LEVI D. WARRINER

EXPIRES: 6-30-2026

PLOT DATE: 5/15/2026

REVISIONS:

DRAWN BY: LDW  
 CHECKED BY: LDW

JOB No: 20115

SCALE: AS SHOWN

SHEET  
**C205**

PRELIMINARY LAND USE

GROSS PLANNING AREA:  
 PARCEL 1 OF PP24-046 AND PORTION OF TAX LOT 3200 (TRACT A OF OAKRIDGE VISTA SUBDIVISION)

GROSS AREA	1,714,957 SF = 39.37 ACRES
REMAINDER OF P1	251,416 SF = 5.77 ACRES
DEVELOPABLE GROSS AREA	1,463,541 SF = 33.60 ACRES
TRACTS	86,247 SF = 1.98 ACRES (5.9%)
	1,377,294 SF = 31.62 ACRES

PLANNING TO BE DEVELOPED:

TOTAL	1,377,294 SF = 31.62 ACRES
PLAT ROADS	301,817 SF = 6.93 ACRES
NET PLANNING AREA	1,075,477 SF = 24.69 ACRES

NET PLANNING AREA:

101 LOTS / 24.69 ACRES	= 4.09 LOTS PER ACRE (NET)
101 LOTS / 31.62 ACRES	= 3.19 LOT PER ACRE (GROSS)
1,075,477 SF / 101 LOTS	= 10,648 SF AVERAGE LOT SIZE
SMALLEST LOT SIZE:	7,264 SF
LARGEST LOT SIZE:	24,550 SF

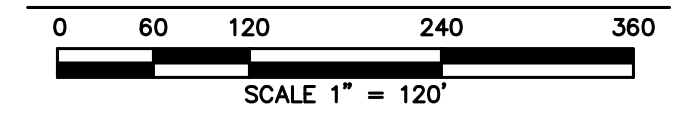

GENERAL NOTES:

1. THE PURPOSE OF THIS PLAN IS TO SHOW THE PROPOSED CONCEPTUAL LAYOUT OF COTTONWOOD RIDGE. THIS IS NOT AN OFFICIAL RECORDED FINAL PLAT AND IS NOT TO BE USED FOR SURVEY PURPOSES. ALL DIMENSIONS ARE SUBJECT TO CHANGE.

TAX LOT 300  
 TAX MAP 091W11A

TAX LOT 402  
 TAX MAP 091W11A  
 PARCEL 2, PP 2024-046  
 37.07 AC

PARCEL 1 PP 2024-046

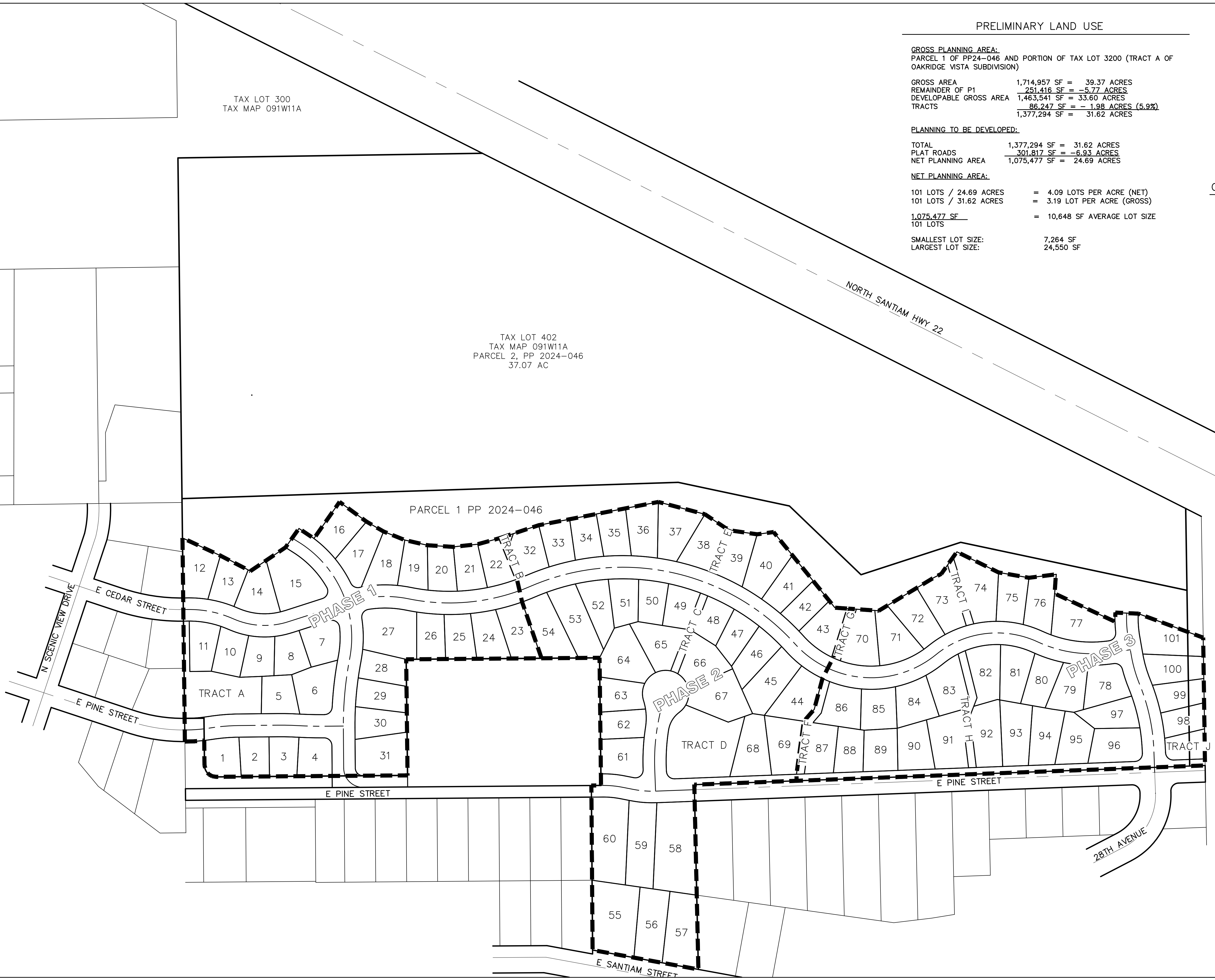

COTTONWOOD RIDGE

CONCEPTUAL  
 PLAN OVERALL



EXPIRES: 6-30-2026  
 PLOT DATE: 5/15/2026  
 REVISIONS:

DRAWN BY: LDW  
 CHECKED BY: LDW  
 JOB No: 20115  
 SCALE: 1" = 120'

SHEET  
**C300**

**NS** NORTH SANTIAM PAVING COMPANY  
 (503) 769-3436  
 LEVIN@NSPOR.COM  
 41203 KINGSTON-LYONS DRIVE, P.O. BOX 516  
 STAYTON, OREGON 97383  
 CONSTRUCTION • ENGINEERING • SURVEYING

CITY OF STAYTON  
 NE 1/4 SEC 11, T9S R1W 11M TAX MAP 091W11A TAX LOT 400  
 MARION COUNTY, OREGON

TAX LOT 402  
 TAX MAP 091W11A  
 PARCEL 2, PP 2024-046  
 37.07 AC

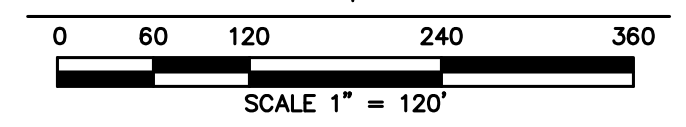

**GENERAL NOTES:**  
 1. THE PURPOSE OF THIS PLAN IS TO SHOW THE PROPOSED CONCEPTUAL LAYOUT OF COTTONWOOD RIDGE. THIS IS NOT AN OFFICIAL RECORDED FINAL PLAT AND IS NOT TO BE USED FOR SURVEY PURPOSES. ALL DIMENSIONS ARE SUBJECT TO CHANGE.

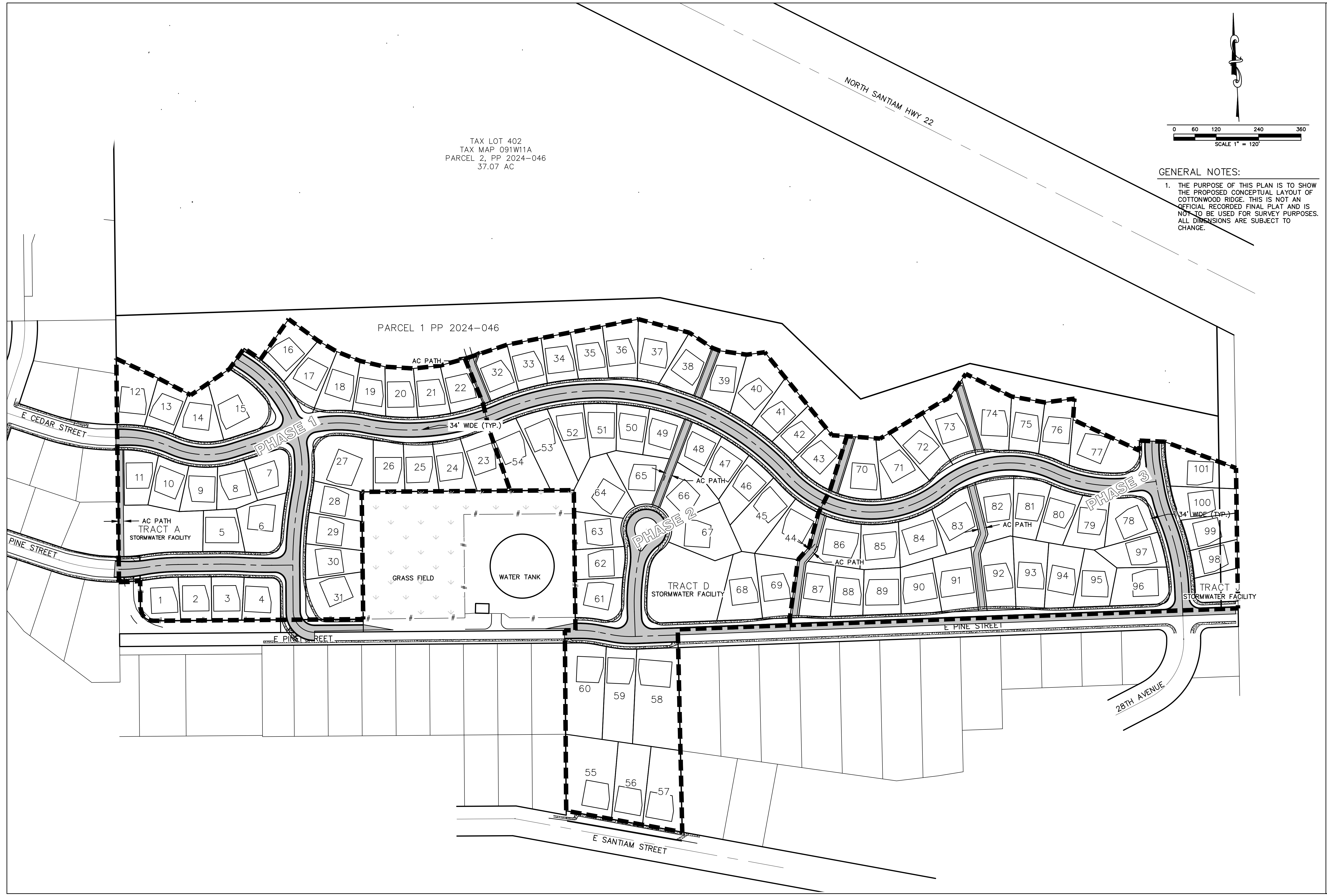

**NS** NORTH SANTIAM PAVING COMPANY  
 (503) 769-3436  
 LEVIN@NSPOR.COM  
 41203 KINGSTON-LYONS DRIVE, P.O. BOX 516  
 STAYTON, OREGON 97383  
 CONSTRUCTION • ENGINEERING • SURVEYING

**COTTONWOOD RIDGE**  
 CITY OF STAYTON MARION COUNTY, OREGON  
 NE 1/4 SEC 11 T9S R1W 11M TAX MAP 091W11A TAX LOT 400

**CONCEPTUAL  
 PLAN OVERALL**



EXPIRES: 6-30-2026  
 PLOT DATE: 5/15/2026  
 REVISIONS:

DRAWN BY: LDW  
 CHECKED BY: LDW  
 JOB No: 20115  
 SCALE: 1" = 120'

SHEET  
**C301**

TAX LOT 402  
 TAX MAP 091W11A  
 PARCEL 2, PP 2024-046  
 37.07 AC

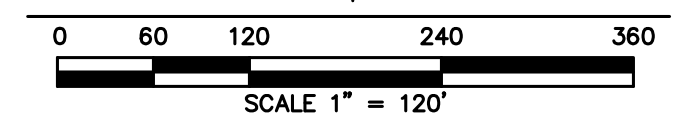

**GENERAL NOTES:**  
 1. THE PURPOSE OF THIS PLAN IS TO SHOW THE PROPOSED CONCEPTUAL LAYOUT OF COTTONWOOD RIDGE. THIS IS NOT AN OFFICIAL RECORDED FINAL PLAT AND IS NOT TO BE USED FOR SURVEY PURPOSES. ALL DIMENSIONS ARE SUBJECT TO CHANGE.



**NS** NORTH SANTIAM PAVING COMPANY  
 (503) 769-3436  
 LEVIN@NSPOR.COM  
 41203 KINGSTON-LYONS DRIVE, P.O. BOX 516  
 STAYTON, OREGON 97383  
 CONSTRUCTION • ENGINEERING • SURVEYING

**COTTONWOOD RIDGE**  
 CITY OF STAYTON MARION COUNTY, OREGON  
 NE 1/4 SEC 11 T9S R1W 11M TAX MAP 091W11A TAX LOT 400

**CONCEPTUAL  
 PLAN OVERALL**



EXPIRES: 6-30-2026  
 PLOT DATE: 5/15/2026  
 REVISIONS:  
 DRAWN BY: LDW  
 CHECKED BY: LDW  
 JOB No: 20115  
 SCALE: 1" = 120'

SHEET  
**C301**



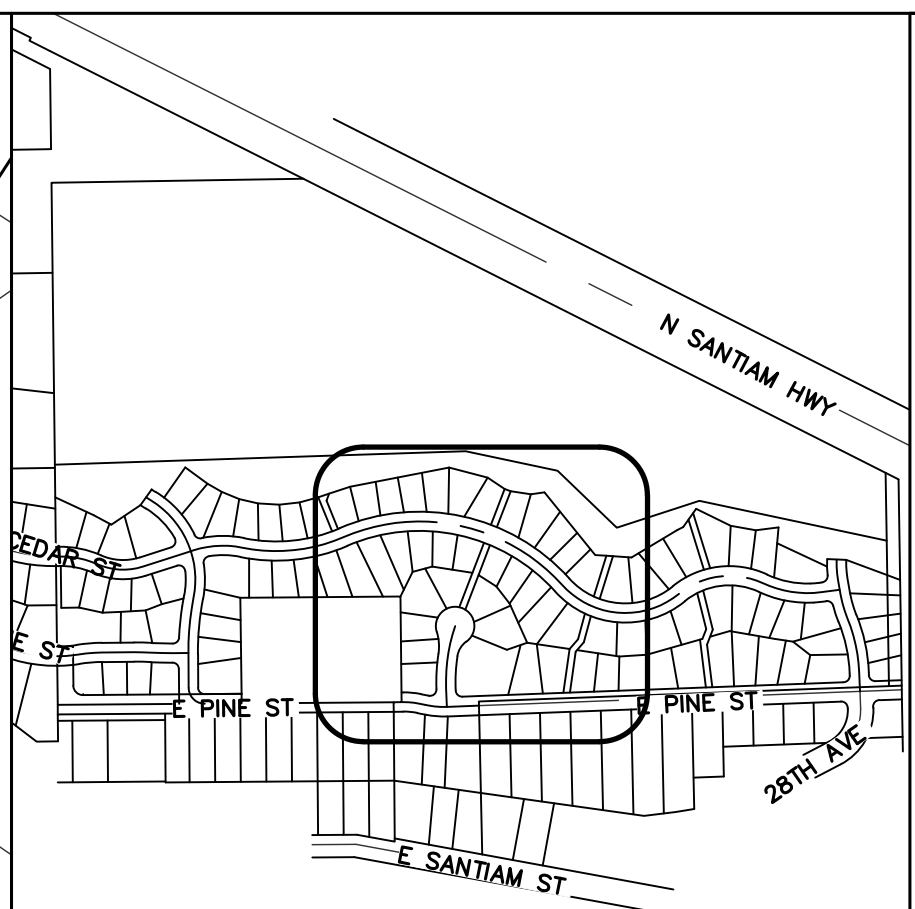
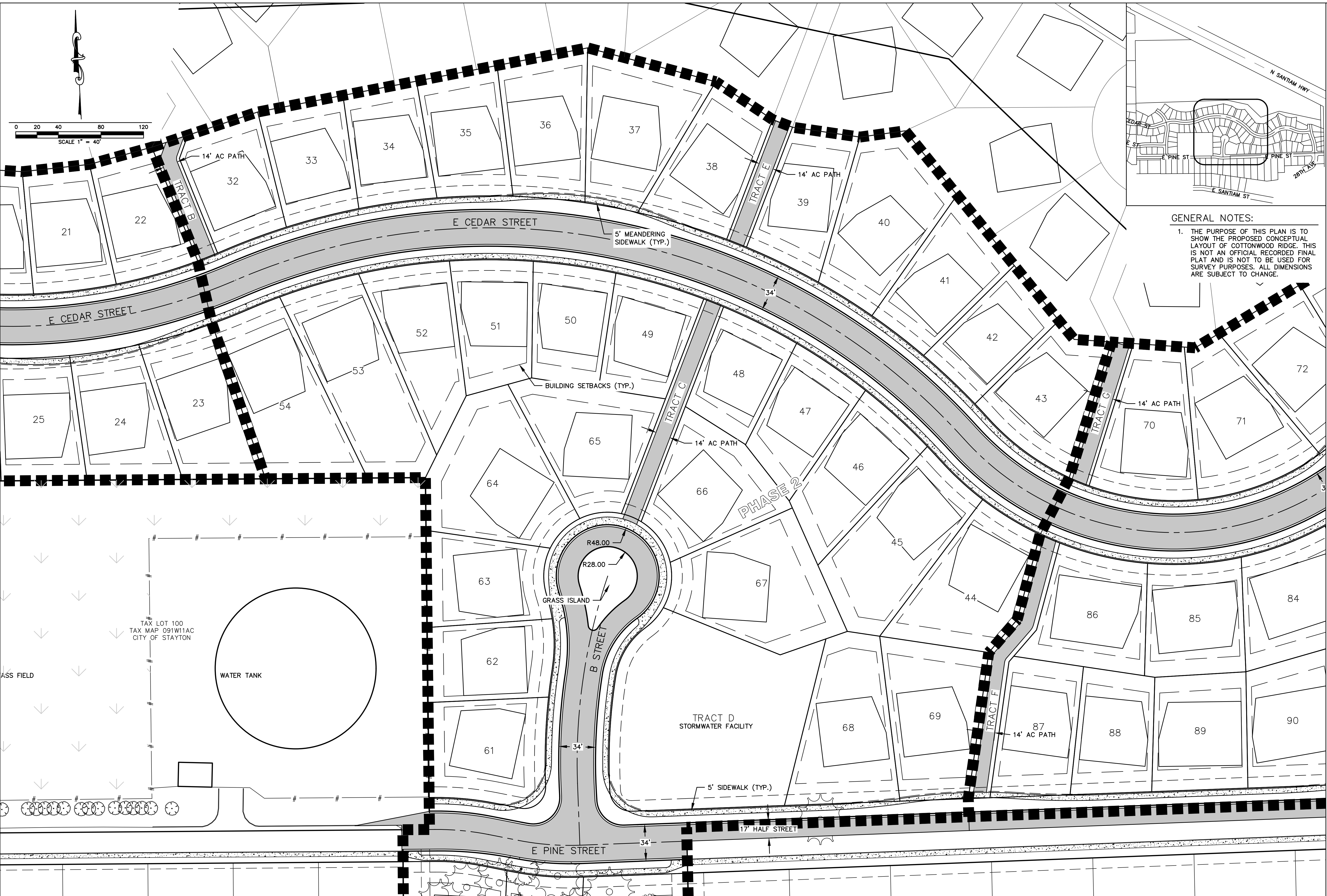

**GENERAL NOTES:**  
 1. THE PURPOSE OF THIS PLAN IS TO SHOW THE PROPOSED CONCEPTUAL LAYOUT OF COTTONWOOD RIDGE. THIS IS NOT AN OFFICIAL RECORDED FINAL PLAT AND IS NOT TO BE USED FOR SURVEY PURPOSES. ALL DIMENSIONS ARE SUBJECT TO CHANGE.

**NS** NORTH SANTIAM PAVING COMPANY  
 (503) 769-3436  
 41203 KINGSTON-LYONS DRIVE, P.O. BOX 516  
 STAYTON, OREGON 97383  
 LEVIN@NSPOR.COM

CONSTRUCTION • ENGINEERING • SURVEYING

**COTTONWOOD RIDGE**

CITY OF STAYTON MARION COUNTY, OREGON  
 NE 1/4 SEC 11 T9S R1W W4 TAX MAP 091W11A TAX LOT 400

**CONCEPTUAL PLAN**

REGISTERED PROFESSIONAL ENGINEER  
 88956PE  
**PRELIMINARY**  
 OREGON  
 JANUARY 21, 2021  
 LEVI D. WARRINER

EXPIRES: 6-30-2026  
 PLOT DATE: 5/15/2026  
 REVISIONS:

DRAWN BY: LDW  
 CHECKED BY: LDW  
 JOB No: 20115  
 SCALE: 1" = 40'  
 SHEET  
**C303**

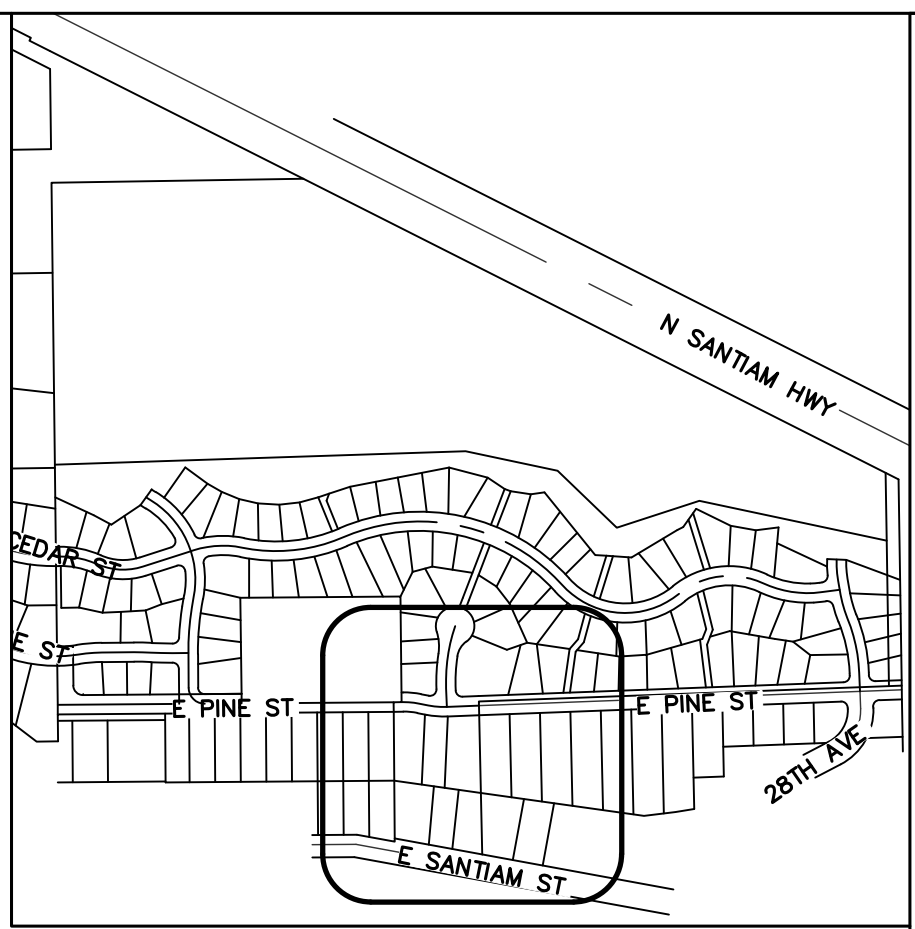
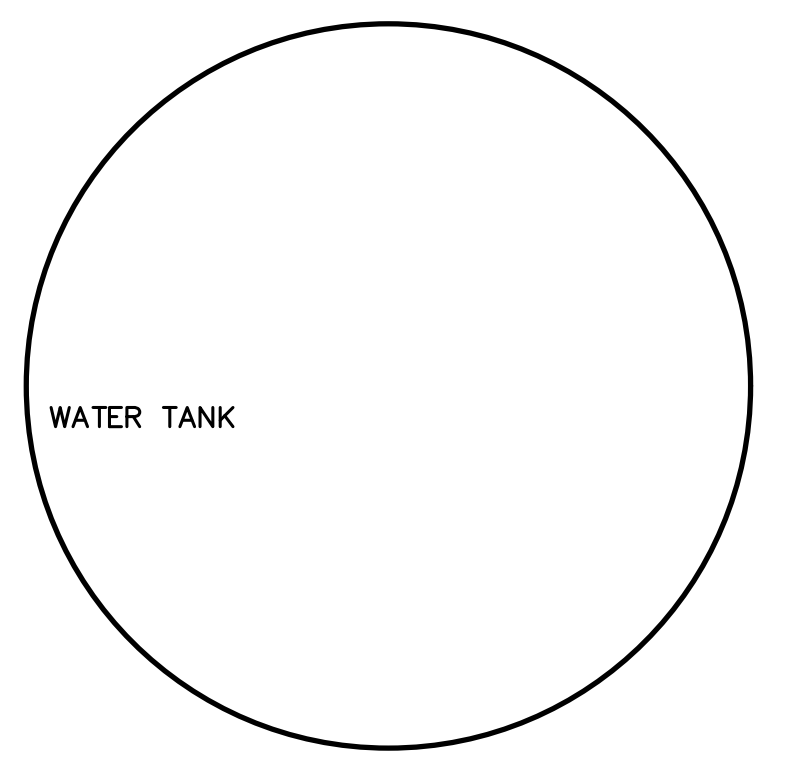
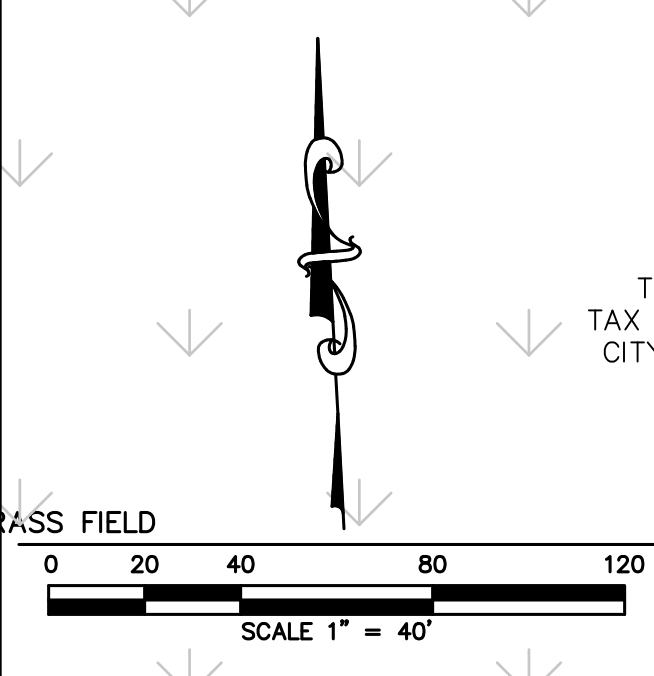

1. THE PURPOSE OF THIS PLAN IS TO SHOW THE PROPOSED CONCEPTUAL LAYOUT OF COTTONWOOD RIDGE. THIS IS NOT AN OFFICIAL RECORDED FINAL PLAT AND IS NOT TO BE USED FOR SURVEY PURPOSES. ALL DIMENSIONS ARE SUBJECT TO CHANGE.

TAX LOT 900  
TAX MAP 091W11AC  
BLOCK 1 LOT 5  
ROCKHAVEN SUB  
D E PINE STREET

TAX LOT 1000  
TAX MAP 091W11AC  
BLOCK 1 LOT 6  
ROCKHAVEN SUB  
2310 E PINE STREET

TAX LOT 1100  
TAX MAP 091W11AC  
BLOCK 1 LOT 7  
ROCKHAVEN SUB  
2360 E PINE STREET

TAX LOT 1200  
TAX MAP 091W11AC  
BLOCK 1 LOT 8  
ROCKHAVEN SUB  
2370 E PINE STREET

TAX LOT 1300  
TAX MAP 091W11AC  
BLOCK 1 LOT 9  
ROCKHAVEN SUB  
2380 E PINE STREET

TAX LOT 1600  
TAX MAP 091W11AC  
BLOCK 2 LOT 9  
ROCKHAVEN SUB  
2355 E SANTIAM STREET

TAX LOT 1500  
TAX MAP 091W11AC  
BLOCK 2 LOT 10  
ROCKHAVEN SUB  
2365 E SANTIAM STREET

TAX LOT 3100  
TAX MAP 091W11AD  
LOT 31 OAKRIDGE VISTA  
2432 E PINE STREET

TAX LOT 3000  
TAX MAP 091W11AD  
LOT 30 OAKRIDGE VISTA  
2456 E PINE STREET

TAX LOT 2900  
TAX MAP 091W11AD  
LOT 29 OAKRIDGE VISTA  
2478 E PINE STREET

TAX LOT 2800  
TAX MAP 091W11AD  
LOT 28 OAKRIDGE VISTA  
2530 E PINE STREET

TAX LOT 2530  
TAX LOT 2531

TAX LOT 100  
TAX MAP 091W11AD  
LOT 1 OAKRIDGE VISTA  
2491 E SANTIAM STREET

TAX LOT 200  
TAX MAP 091W11AD  
LOT 2 OAKRIDGE VISTA  
2495 E SANTIAM STREET

TAX LOT 300  
TAX MAP 091W11AD  
LOT 3 OAKRIDGE VISTA  
2511 E SANTIAM STREET

**NS** NORTH SANTIAM PAVING COMPANY  
 (503) 769-3436  
 LEVIN@NSPC.COM  
 41203 KINGSTON-LYONS DRIVE, P.O. BOX 516  
 STAYTON, OREGON 97383

CONSTRUCTION • ENGINEERING • SURVEYING

**COTTONWOOD RIDGE**

CITY OF STAYTON MARION COUNTY, OREGON  
 NE 1/4 SEC 11 T9S R1W 11M TAX MAP 091W11A TAX LOT 400

**CONCEPTUAL PLAN**



EXPIRES: 6-30-2026  
 PLOT DATE: 5/15/2026  
 REVISIONS:  
 \_\_\_\_\_  
 \_\_\_\_\_  
 \_\_\_\_\_  
 \_\_\_\_\_  
 \_\_\_\_\_  
 DRAWN BY: LDW  
 CHECKED BY: LDW  
 JOB No: 20115  
 SCALE: 1" = 40'

SHEET  
**C304**

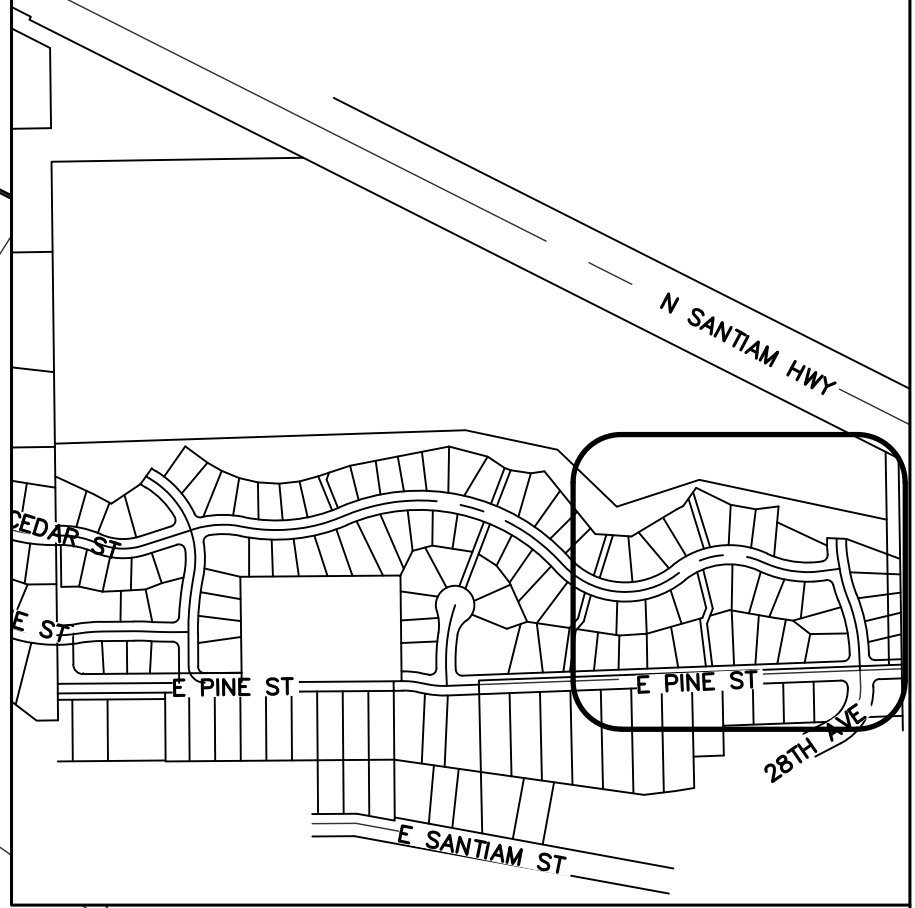
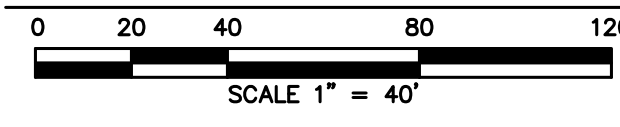
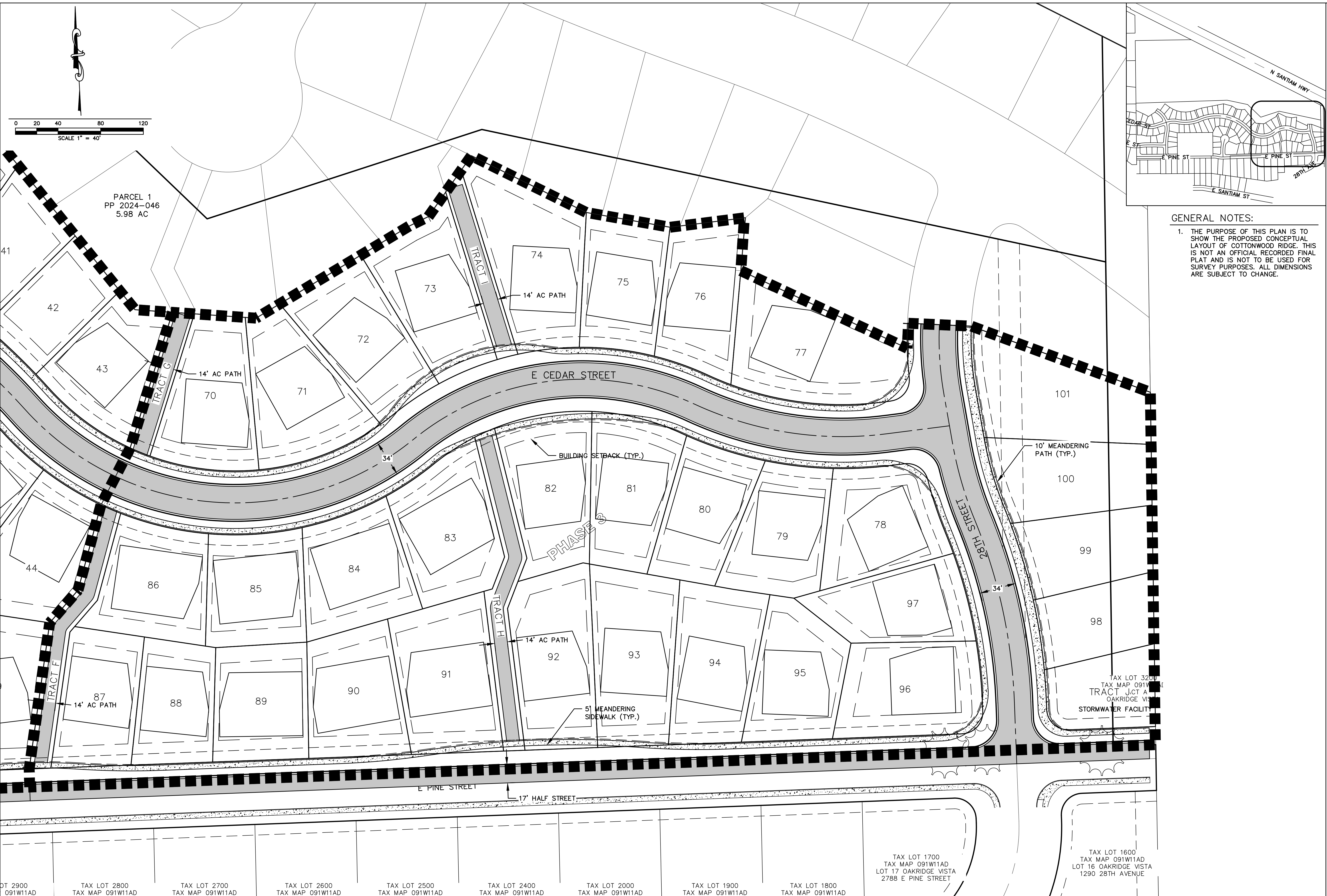

**GENERAL NOTES:**

1. THE PURPOSE OF THIS PLAN IS TO SHOW THE PROPOSED CONCEPTUAL LAYOUT OF COTTONWOOD RIDGE. THIS IS NOT AN OFFICIAL RECORDED FINAL PLAT AND IS NOT TO BE USED FOR SURVEY PURPOSES. ALL DIMENSIONS ARE SUBJECT TO CHANGE.

DT 2900 091W11AD    TAX LOT 2800 TAX MAP 091W11AD    TAX LOT 2700 TAX MAP 091W11AD    TAX LOT 2600 TAX MAP 091W11AD    TAX LOT 2500 TAX MAP 091W11AD    TAX LOT 2400 TAX MAP 091W11AD    TAX LOT 2000 TAX MAP 091W11AD    TAX LOT 1900 TAX MAP 091W11AD    TAX LOT 1800 TAX MAP 091W11AD

**NS** NORTH SANTIAM PAVING COMPANY  
 (503) 769-3436  
 LEVIN@NSPC.COM  
 41203 KINGSTON-LYONS DRIVE, P.O. BOX 516  
 STAYTON, OREGON 97383  
 CONSTRUCTION • ENGINEERING • SURVEYING

**COTTONWOOD RIDGE**  
 CITY OF STAYTON    MARION COUNTY, OREGON  
 NE 1/4 SEC 11 T9S R1W 11M TAX MAP 091W11A TAX LOT 400

**CONCEPTUAL PLAN**



PRELIMINARY  
 EXPIRES: 6-30-2026  
 PLOT DATE: 5/15/2026  
 REVISIONS:

DRAWN BY: LDW  
 CHECKED BY: LDW  
 JOB No: 20115  
 SCALE: 1" = 40'

SHEET  
**C305**

PRELIMINARY LAND USE

GROSS PLANNING AREA:  
 PARCEL 1, PARCEL 2 OF PP24-046, PORTION OF TAX LOT 300,  
 PORTION OF TAX LOT 3200 (TRACT A OF OAKRIDGE VISTA SUBDIVISION)

GROSS AREA 3,454,308 SF = 79.30 ACRES  
 TRACTS 227,300 SF = 5.22 ACRES (6.6%)  
 3,227,008 SF = 74.08 ACRES

PLANNING TO BE DEVELOPED:

TOTAL 3,227,008 SF = 74.08 ACRES  
 PLAT ROADS 733,837 SF = 16.85 ACRES  
 NET PLANNING AREA 2,493,171 SF = 57.23 ACRES

NET PLANNING AREA:

259 LOTS / 57.23 ACRES = 4.53 LOTS PER ACRE (NET)  
 259 LOTS / 74.08 ACRES = 3.50 LOT PER ACRE (GROSS)  
 2,493,171 SF / 259 LOTS = 9,626 SF AVERAGE LOT SIZE  
 SMALLEST LOT SIZE: 5,150 SF  
 LARGEST LOT SIZE: 24,450 SF

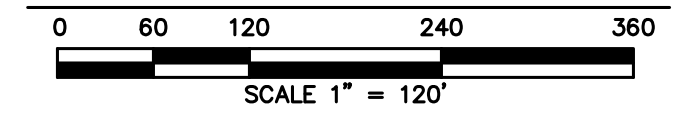

GENERAL NOTES:

1. THE PURPOSE OF THIS PLAN IS TO SHOW THE PROPOSED CONCEPTUAL LAYOUT OF COTTONWOOD RIDGE. THIS IS NOT AN OFFICIAL RECORDED FINAL PLAT AND IS NOT TO BE USED FOR SURVEY PURPOSES. ALL DIMENSIONS ARE SUBJECT TO CHANGE.

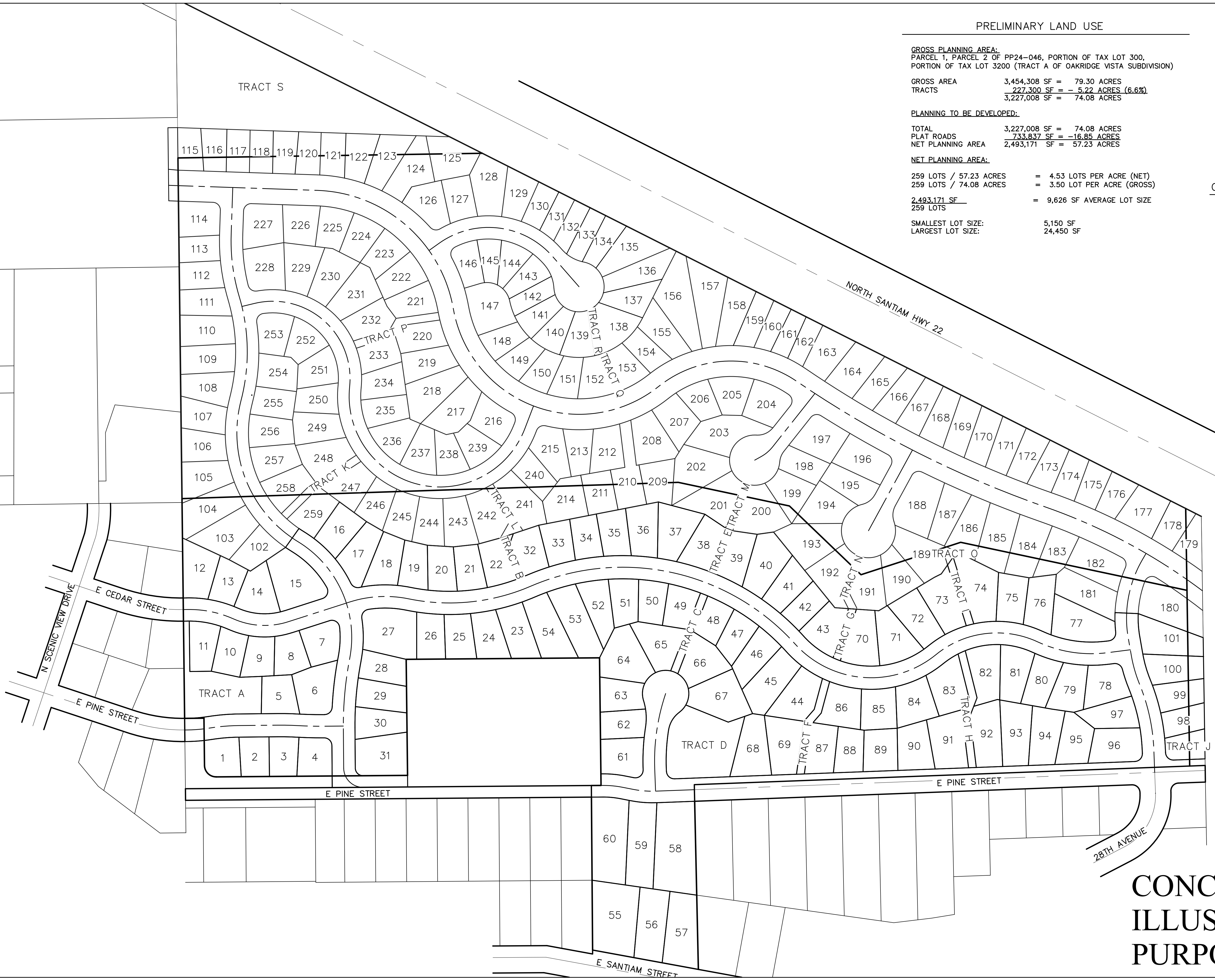

CONCEPTUAL. FOR  
 ILLUSTRATION  
 PURPOSES ONLY

**NS** NORTH SANTIAM PAVING COMPANY  
 (503) 769-3436  
 LEVIN@NSPOR.COM  
 41203 KINGSTON-LYONS DRIVE, P.O. BOX 516  
 STAYTON, OREGON 97383  
 CONSTRUCTION • ENGINEERING • SURVEYING

COTTONWOOD RIDGE

CONCEPTUAL  
 PLAN OVERALL



EXPIRES: 6-30-2026

PLOT DATE: 5/15/2026

REVISIONS:

DRAWN BY: LDW  
 CHECKED BY: LDW

JOB No: 20115

SCALE: 1" = 120'

SHEET  
**C300**

CITY OF STAYTON MARION COUNTY, OREGON  
 NE 1/4 SEC 11 T9S R1W 11M TAX MAP 091W11A TAX LOT 400

TRACT S  
STORMWATER FACILITY  
AND NEIGHBORHOOD  
PARK  
2.7 AC

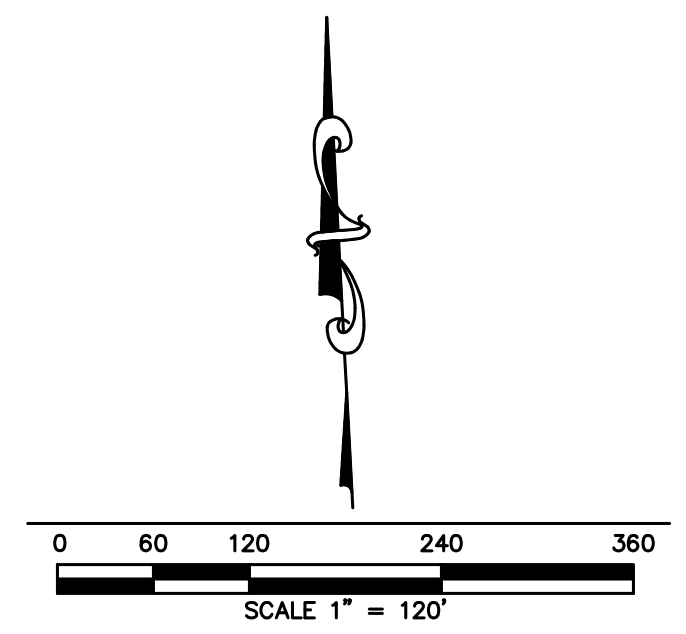

GENERAL NOTES:  
1. THE PURPOSE OF THIS PLAN IS TO SHOW THE PROPOSED CONCEPTUAL LAYOUT OF COTTONWOOD RIDGE. THIS IS NOT AN OFFICIAL RECORDED FINAL PLAT AND IS NOT TO BE USED FOR SURVEY PURPOSES. ALL DIMENSIONS ARE SUBJECT TO CHANGE.

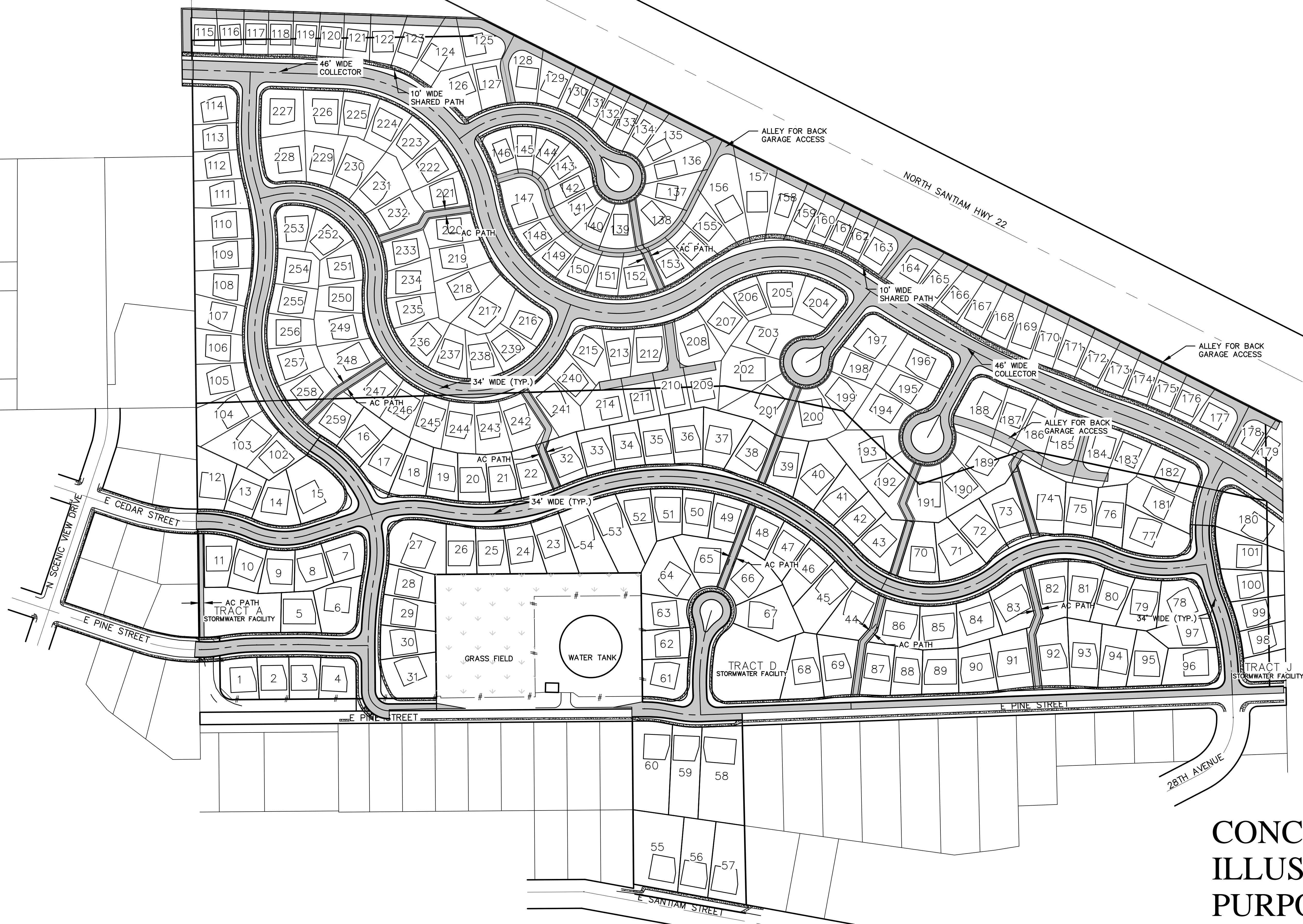

**NS** NORTH SANTIAM PAVING COMPANY  
(503) 769-3436  
LEVW@NSPOR.COM  
41203 KINGSTON-LYONS DRIVE, P.O. BOX 516  
STAYTON, OREGON 97383  
CONSTRUCTION • ENGINEERING • SURVEYING

COTTONWOOD RIDGE  
MARION COUNTY, OREGON  
CITY OF STAYTON  
NE 1/4 SEC 11, T9S R1W W4 TAX MAP 091W11A TAX LOT 400

**CONCEPTUAL  
PLAN OVERALL**

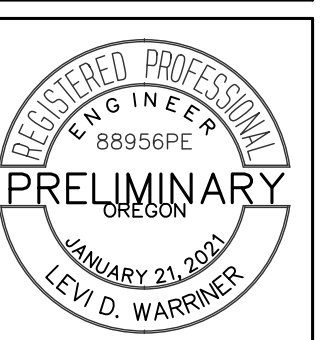

EXPIRES: 6-30-2026  
PLOT DATE: 5/15/2026  
REVISIONS:

DRAWN BY: LDW  
CHECKED BY: LDW  
JOB No: 20115  
SCALE: 1" = 120'

SHEET  
**C301**

**CONCEPTUAL. FOR  
ILLUSTRATION  
PURPOSES ONLY**